

desco drill rig

Desco Inc.(HQ/Manufacturer)
HEAD OFFICE: 1240-1, Ok-Dong, Gwangsan, Gwangju, Korea
TEL : 82.62.952.4564 / FAX : 82.62.953.1593

EXPORT DIVISION
2607 jidong, Lottecastle, 76, Soongin-Dong, Jongno-Gu, Seoul, Korea
TEL : 82-2-3670 6400 / FAX : 82-2-3670 6399
E-mail : desco@desco-inc.com



SP7000

Geothermal & waterwell Drilling



SP7000 (Most powerful)

As one of the most power drills upto 600M depth for waterwell & geothermal, the SP7000 delivers super power in a compact package.

Compactable size enables drillers to easily operate & manage in working place

SP7000 features a pullback capacity of 25 ton and a torque can be increased

SP7000 can also include a advanced rod management system that ensures safe and efficient operation

A radio remote safely positions the driller away from the rig during traveling

- * SP7000 for waterwell & geothermal drilling
- * Design for drilling up to 600M with dia. 8" and up to dia. 18"
- * Percussion drilling methods
- * Rotary drilling methods
- * Auger drilling methods
- * All instrument & control levers are concentrated.
- * Mounted full package on drill rig
- * Self-loading system
- * Easy to repair the machine by yourself due to full Hyd. system
- * Installed major hyd. Parts so easy to find spare parts in the market
- * Options - inverter, auto rod changer, pre-heating system, wireless remote control and so on

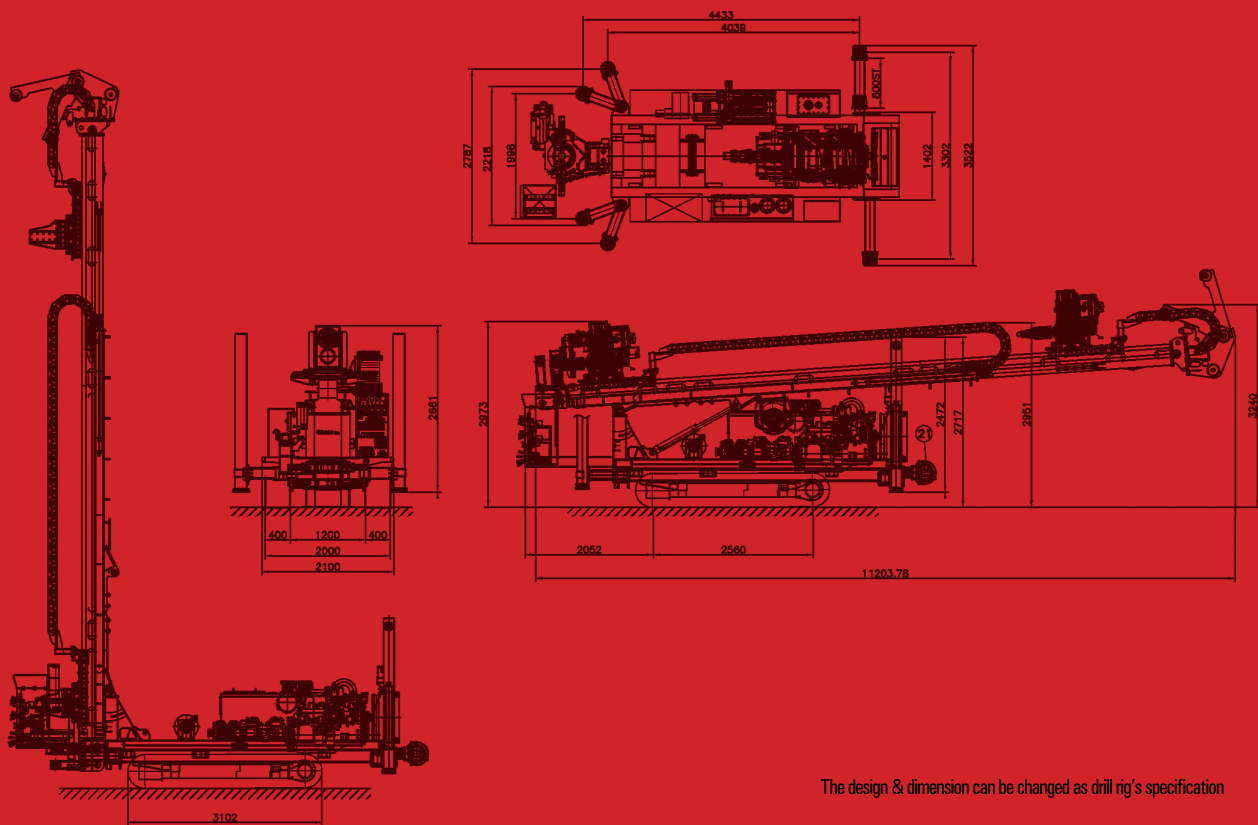

The design & dimension can be changed as drill rig's specification

If you want the kind of drill rigs,
DESCO INC. is at your solution and service.



desco drill rig

TECHNICAL SPECIFICATION

Top head rotation

Rotation torque
Rotation speed
Rotation speed & torque can be controlled

Two speed motors

1000kg.M (low) / 500kg.M (high)
0 ~ 60 rpm (low) / 0 ~ 120 (high)

Feed System

Feed system type
Feed hydraulic cylinder
Feed stroke
Pull-back force
Down force

Variable Speed Hydraulic Cylinder
150mm*110mm*3750mm
7.5M (Drill Pipe - Max. 6.0M)
25ton
12ton

Dimension & Weight

Net weight
Width
Length (mast folded / unfolded)
Height (mast folded / unfolded)

16.5ton
2.3M
10.5M
2.8M

Engine

Engine model
Engine power
Cooling system
Fuel tank
Electrical system

Hyundai D6AZ
270HP@1800rpm
Water
300 Liters
24V DC

Hydraulic system

General
Pump model
System hyd. oil flow
Hydraulic tank
Operating pressure

Single variable displacement pump, pressure & flow controlled
K3V140*2+28*2 (4 pumps)
480LPM
400 Liters
280 Bar

Working table & hyd. clmap

Max. diameter
Hyd clamp

18"
18"

Outrigger

Four hyd. Jacks & outriggers - Front jacks & outriggers (swing 45⁰)
Ground clearance
Width

800mm
3000mm

Crawler base

Doosan model (Steel)

Main hoist

Hoist type
Linepull capacity
Spool capacity

Variable speed planetary c/w brake
10ton
14mm * 30M

Mud pump

Hydraulic cylinder operated duplex piston pump
Capacity
Max. pressure

800 LPM
40 bar

If you want the kind of drill rigs, DESCO INC. is at your solution and service.

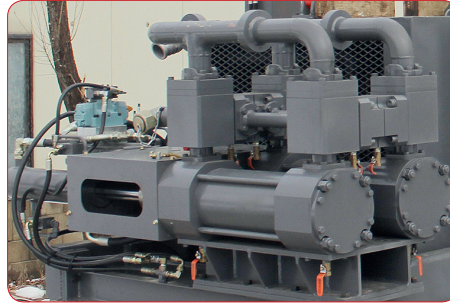

STANDARD / OPTIONAL

	STANDARD	OPTIONAL	OPTIONAL REQUEST
Drill head			
Drill head	DSDH-900	DSDH-1000	
Drill head - sliding	0		
Feed system			
Mast slide (dump up and down)	0		
Bolted mast foot	0		
Control panel	0		
Hydraulic system			
Auxiliary hydraulic ports		0	
Hydraulic breakout table			
Max. diameter	max. 18"	over 18"	
Single clamp	0		
Double clamp		0	
Crawler base			
Steel track	0		
Steel track with rubber pad		0	
Main hoist			
Main winch	max. 10ton	over 10ton	
Sub winch		0	
Mud pump			
Capacity	800LPM	1000LPM	
Water injection pump		0	
Inverter (5.5kw / 100V ~ 220V)		0	
DTH oil lubricator		0	
Auto rod changer		0	
Preheating system		0	
Wireless remote travel		0	
Safety cage		0	

Notice As your optional list, engine, hyd. system, crawler and so on can be changed and design of drill rigs can be changed.

Specifications are general and subject to change without notice. Due to selected options, delivered equipment may not necessarily match that shown.

